



# 008 Silver Airless Spray Gun





# WARNINGS - READ FIRST BEFORE USING PRODUCT

- ⚠ High pressure spray can cause extremely serious injuries such as amputation.
- ⚠ Handle the spray gun as you would a loaded firearm!! Read and understand all instruction manuals, tags, warnings, users guides & labels supplied with the spray gun, airless pump, hoses, spray tips & any other attachments before operating equipment.
- ⚠ Learn & follow “Pressure Relief Procedure” of the equipment in use. Never attempt to change or clean the spray tip or service unit & gun without first releasing pressure. If “Pressure Relief Procedure” is not known, contact pump manufacturer for instruction. Never leave pressure in the system while not in use.
- ⚠ Airlessco spray guns are designed for use with Airlessco spray tips only.
- ⚠ If any other attachments are used, the spray gun is considered to be modified and safe operation is now limited to the safety of the attachment.
- ⚠ For safe renting of airless equipment, use rental instructions, warnings and forms supplied by airless pump manufacturer
- ⚠ Be sure that all safety devices are operating properly before each use.

## PRESSURE RELIEF PROCEDURE

### ⚠ IMPORTANT!

To avoid possible serious body injury, always follow this procedure whenever the sprayer is shut off, when checking it, when installing, changing or cleaning tips, whenever you stop spraying, or when you are instructed to relieve the pressure.

1. Engage gun safety latch.
2. Turn unit off and unplug from electrical outlet.
3. Disengage gun safety latch and trigger gun to relieve residual fluid pressure.

*Hold metal part of the gun in contact with grounded metal pail. USE MINIMUM PRESSURE !*



4. On Airlessco Model Paint Sprayers turn Prime/Pressure Relief Valve (PR Valve) to the open (priming) position to relieve residual fluid pressure. (PR Valves on sprayers made by other manufacturers may operate differently.)

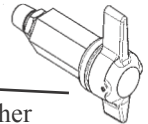

**There will be a wider gap between valve handle and cam body when in open position. In the closed position there is only a very slight gap.**

**Note: The valve handle can move both clockwise and counter clockwise and can face different directions.**

5. Re-engage gun safety latch and close Prime/Pressure Relief Valve.

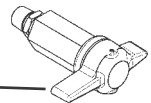

If the **SPRAY TIP OR HOSE IS CLOGGED**, follow Step 1 through 5 above. Expect paint splashing into the bucket while relieving pressure during Step 4.

If you suspect that pressure hasn't been relieved due to damaged Prime/Pressure Relief Valve or other reason, engage the gun safety latch and take your unit to an authorized Airlessco Service Center.

Manufactured by: AIRLESSCO BY DUROTECH CO.

P.O. Box 8006, Moorpark, CA. 93020-8006, Ship to: 5397 Commerce Ave., Moorpark, CA 93021 Tel: 805-523-0211 Fax: 805-523-1063  
SUBJECT TO CHANGE WITHOUT NOTICE.

Copyright © 2004, Airlessco by Durotech. All rights reserved.



# 008 SILVER GUN OPERATION

## SPRAY GUN

Attach spray gun to airless unit and tighten fittings securely. Set the gun safety latch. (Also may be called gun safety lock, or trigger lock)

\* The gun safety latch should always be set when the gun is not being triggered.

Read all warnings and safety precautions supplied with the spray gun and in product manual.

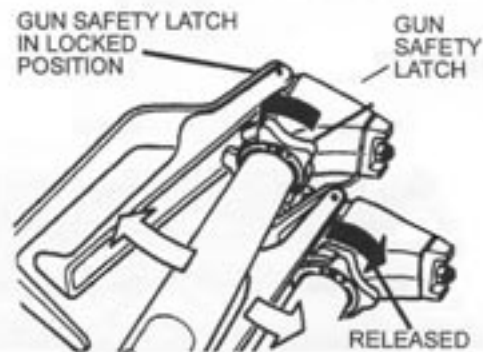

## MAJOR COMPONENTS OF SPRAY GUN AND REVERSIBLE SPRAY TIP

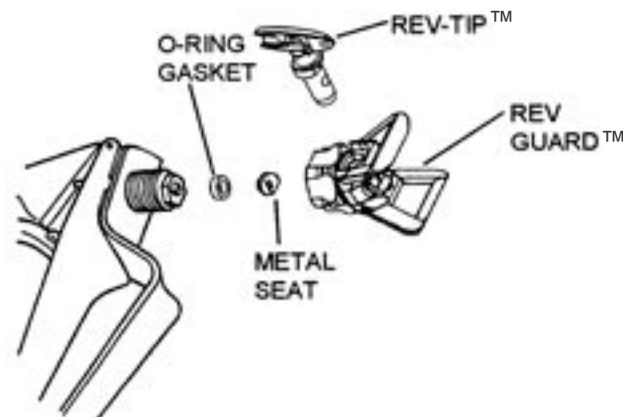
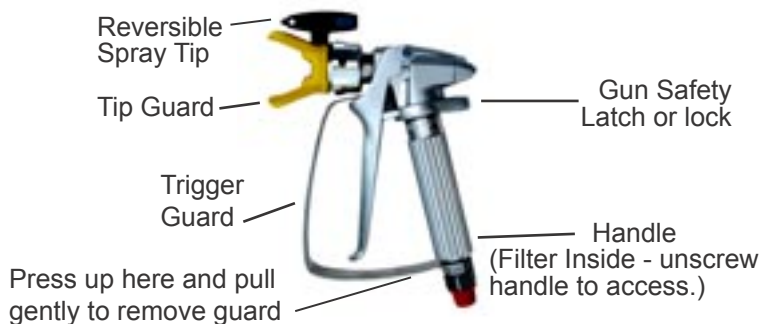

## SPRAY TIP ASSEMBLY

1. Be sure the pressure relief procedure is followed before assembling tip and housing to the gun.
2. Insert REV-TIP™ cylinder into the REV-GUARD™ (guard housing assembly).
3. Guide the metal seat into REV-GUARD™ (guard housing assembly) through the retaining nut and turn until it seats against the cylinder.
4. Insert the O-Ring gasket onto the metal seat so that it fits into the grooves.
5. Finger tighten REV-GUARD™ retaining nut onto the gun.
6. Turn guard in the desired position.
7. Completely tighten the retaining nut.

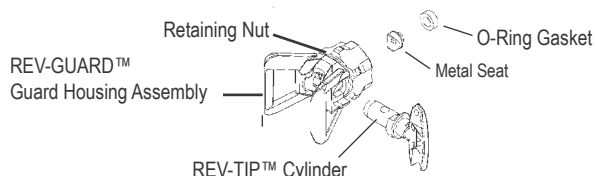

## TO REMOVE CLOGS FROM SPRAY TIP

1. Lock gun safety latch.
2. Turn REV-TIP™ handle 180 degrees.
3. Disengage trigger lock and trigger gun into the pail.
4. If the REV-TIP™ handle appears locked (resists turning), loosen the retaining nut. The handle will now turn easily.
5. Engage gun safety latch and return handle to the spray position.

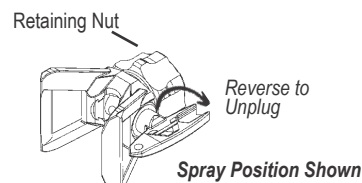

## CLEANING SPRAY GUN

Immediately after the work is finished, flush the gun out with a solvent. Brush pins with solvent and oil them lightly so they will not collect dried paint.

## CLEANING FILTER IN GUN HANDLE

To clean the filter, use a brush dipped in an appropriate solvent. Change or clean filters at least once a day. Some types of latex may require a filter change after four hours of operation.

## CLOGGED FLAT TIP

Should the spray tip become clogged, relieve pressure from hose by following the "Pressure Relief Procedure." Secure gun with the safety latch, take off guard, take out the tip, soak in appropriate solvent & clean with a brush. (Do not use a needle or sharp pointed instrument to clean the tip. The tungsten carbide is brittle and can chip.)

# SPRAY TECHNIQUE

Good spray gun technique is at the core of any spray paint operation. Operator skill and efficiency is as important as good equipment and good paint. Good spray technique is a skill that can be quickly learned by following these simple instructions.

If you are not familiar with spraying techniques, we recommend that you study this section of your manual and practice the proper technique on pieces of cardboard or a suitable surface.

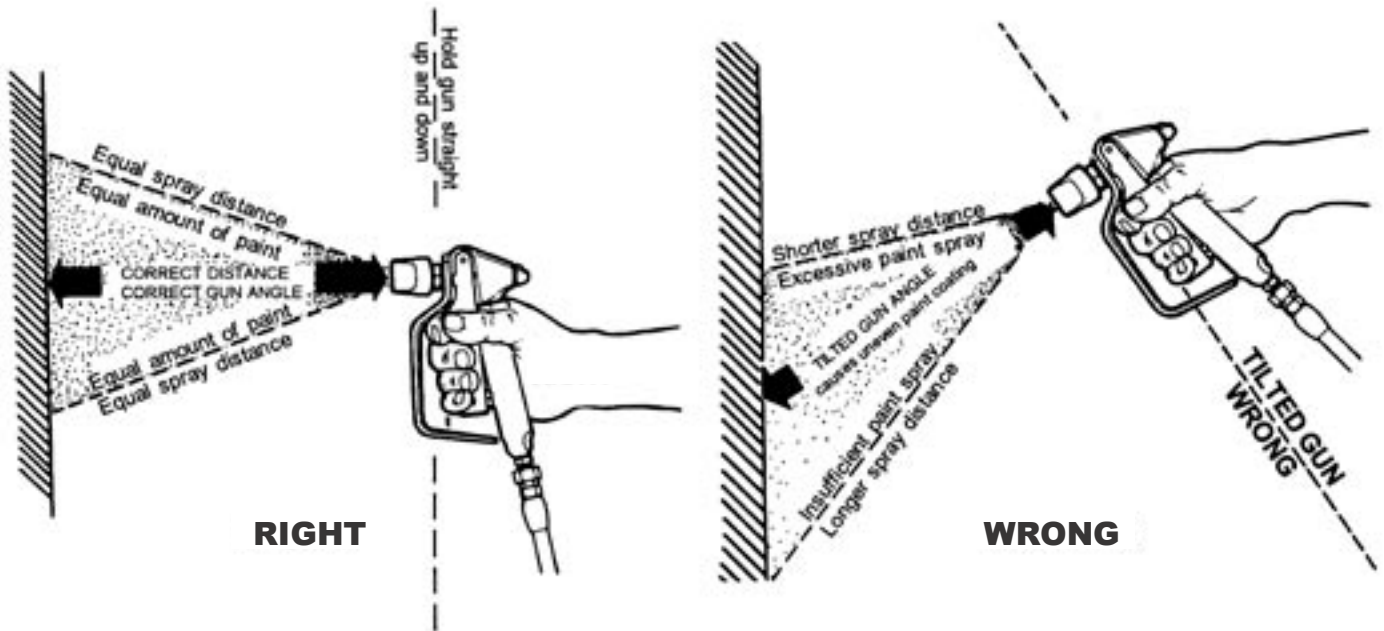

Hold the spray gun 12 - 15 inches away from the work surface and keep it perpendicular (straight) to the surface. Move the spray gun parallel to the work and at a right angle to the surface.

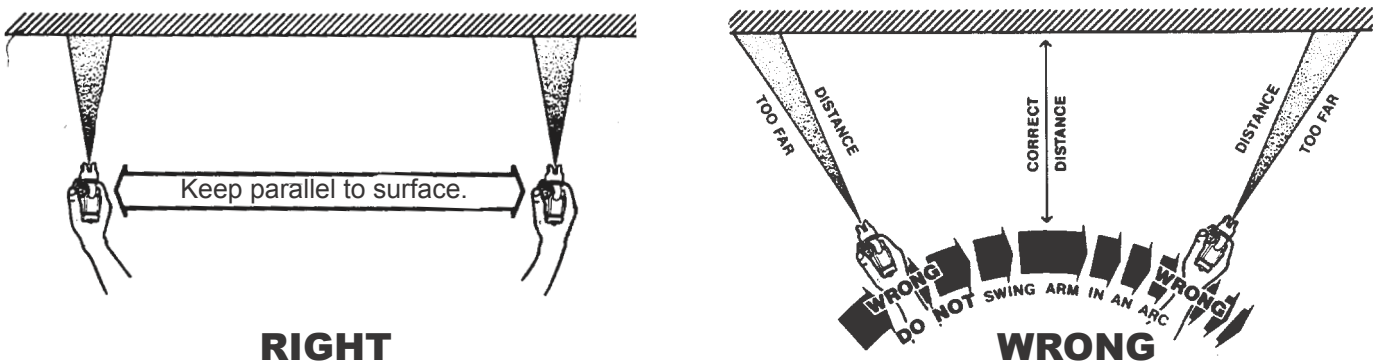

Move the gun at a steady rate in order to apply a good coverage. The wet coat should be just under the thickness at which a run or sag will occur. Slow gun movement or gun held too close will result in an overly wet or thick coat coverage that is likely to run or sag.

Do not wave the spray gun. This waving is called arching. Instead, hold the spray gun at a 12 to 15 inch distance perpendicular from the work.

The closer the spray gun is held to the work, the thicker the paint is deposited and the faster the gun must be moved to prevent sags and runs. Holding the gun too far from the work will cause excessive fog, overspray, and a thin and grainy coat.

# SPRAY TECHNIQUE

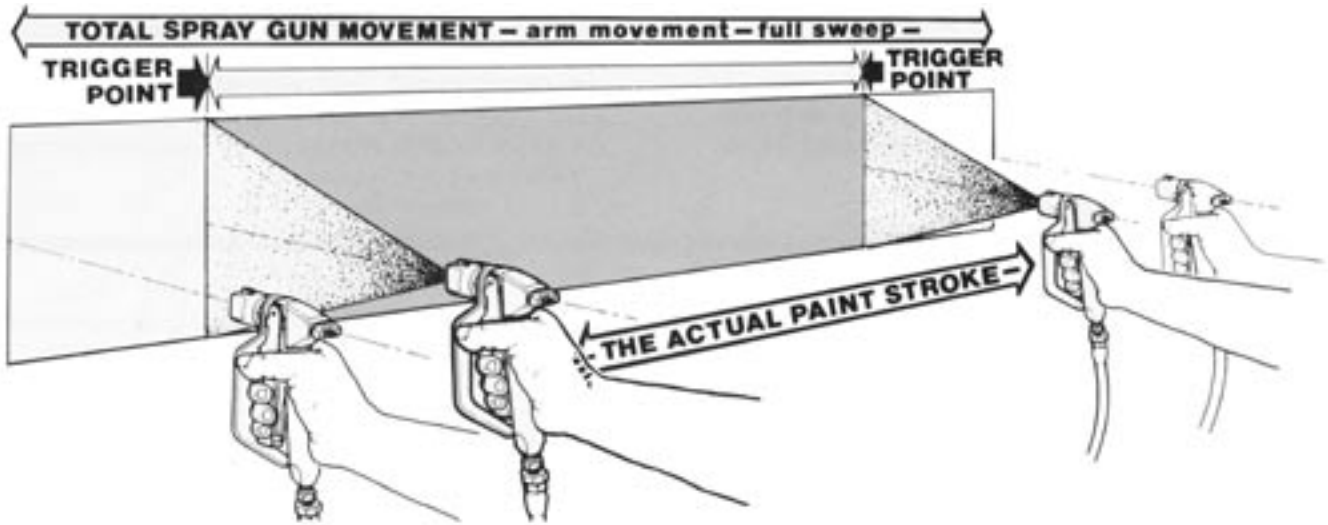

It is important to “trigger” the gun after the gun movement (arm movement) has started and release trigger (shut gun off) before gun movement ends. Gun movement is always longer than actual paint (spray) stroke. In that manner, even blending and uniform paint coat thickness is achieved over the entire surface. When the gun is in motion as the trigger is pulled, it deposits an even amount of paint.

Overlap the previous pass by 1/3 the width of the spray pattern. Aim at the bottom of the previous pass.

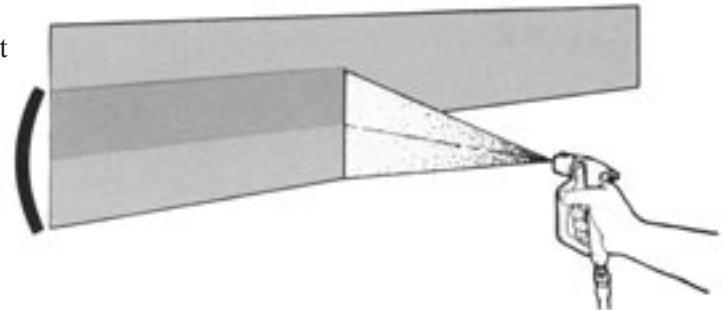

Spray with uniform strokes from left to right and from right to left, holding same stroke speed, distance, lapping and triggering as uniform as possible.

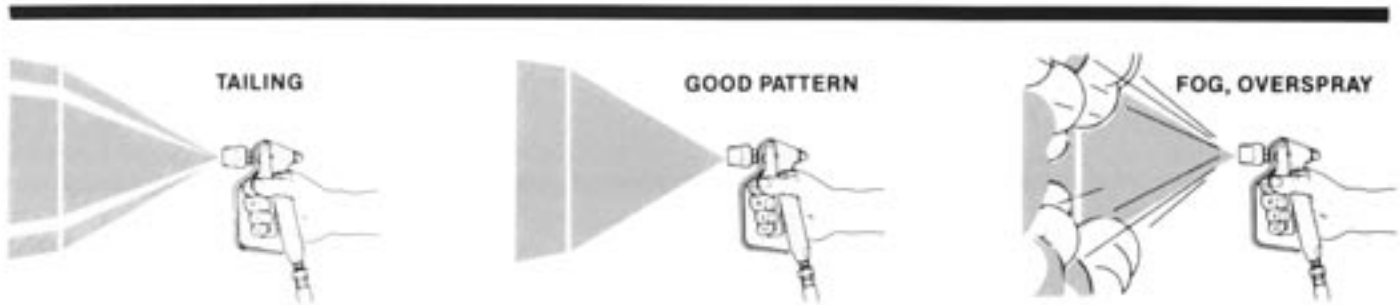

Adjust pressure control knob so that the paint is completely atomize from the spray gun. Insufficient pressure will result in “tailing.” Too much pressure will result in excess fog and over-spray, excessive tip wear & increased sprayer wear & tear.

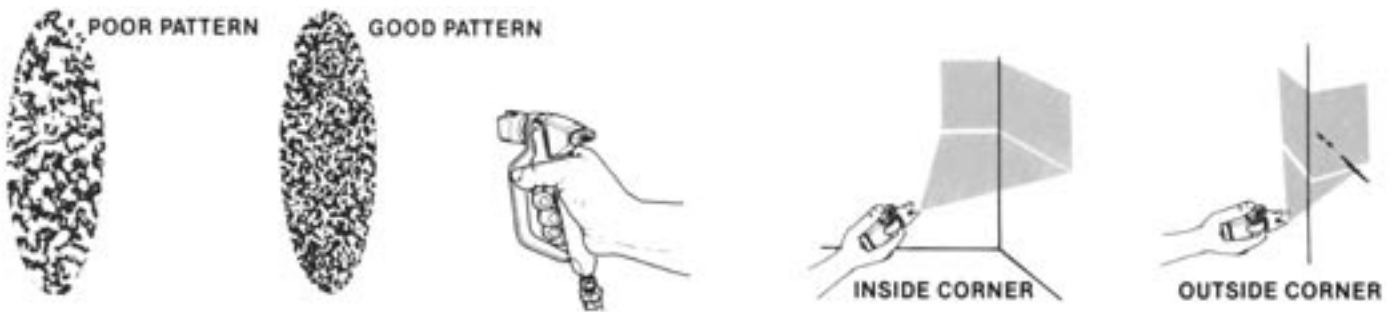

- Always use the lowest pressure possible to obtain desirable results.
- Test spray pattern on a piece of cardboard or other surface.

- “Inside” and “outside” corners can be sprayer.
- Aim the spray gun toward the center of the corner. The spray pattern is divided in half, and the edges of the spray pattern on both walls are the same.

# AIRLESS SPRAY GUN TROUBLESHOOTING

<b><u>DEFECTS</u></b>	<b><u>CAUSE</u></b>	<b><u>CORRECTION</u></b>
<b>Coarse spray</b>	Low pressure	Increase the pressure.
<b>Excessive fogging (overspray)</b>	High pressure Material too thin	Reduce pressure for satisfactory pattern. Use less thinner.
<b>Pattern too wide</b>	Spray angle too large	Use smaller spray angle tip.
<b>Pattern too narrow</b>	Spray angle too small	Use larger spray angle tip. (If coverage is OK, try tip in same nozzle group)
<b>Too much material</b>	Nozzle too large Material too thin Pressure too high	Use next smaller nozzle. Reduce pressure.
<b>Too little material</b>	Nozzle too small Material too thick	Use next larger nozzle.
<b>Thin distribution in center of pattern "horns"</b>	Worn tip Wrong tip	Change for new tip. Use nozzle with a narrow spray angle.
<b>Thick skin on work</b>	Material too viscous Application too heavy	Thin cautiously. Reduce pressure and/or use tip in next larger nozzle group.
<b>Coating fails to close &amp; smooth over</b>	Material too viscous	Thin cautiously.
<b>Spray pattern irregular, deflected</b>	Orifice clogged Tip damaged	Clean carefully. Replace with new tip.
<b>Craters or pock marks, bubbles on work</b>	Solvent balance	Use 1 to 3% "short" solvents remainder "long" solvents. (Most likely to happen with material of low viscosity, lacquers etc.).
<b>Clogged screens</b>	Debris in paint Coarse paint pigments Incompatible paint mixture & thinners.	Clean screen. Use coarse gun filter screen. Use coarser screen for larger orifice tips. If thinner was added, test to see if a drop on top of paint mixes or flattens out on the surface. If not, try different thinner in fresh batch of paint.

## TEST THE PATTERN

Good, full



Spotty Pattern  
Increase Pressure.



# GUN DISMANTLING AND REASSEMBLY



**IMPORTANT NOTE:** Whenever working on Airless Equipment, be sure to follow the Pressure Relief Procedure found in your manual. If the gun is attached to a sprayer, engage the gun trigger lock (which may be called the gun safety latch). The gun trigger lock should always be set when the gun is not being triggered.

## REPLACING THE VALVE SPRING UNIT

### Dismantling:

1. Unscrew the REV-GUARD™ and remove the spray tip & seal.
2. Pulling the trigger, unscrew the Valve Seat using a 5/8" socket wrench.
3. Unscrew the retainer nut, remove the retainer and retainer pins then push the shaft of the valve spring unit out of the gun head.
4. Clean the Gun Head bore with solvent and a small brush. Do not use any sharp objects to scrape away dried paint; doing so may cause damage to the gun head, causing a leak around the seal.

### Reassembling:

1. Apply grease to the O-Ring then push valve spring unit firmly into gun head by hand.
2. Reinstall the retainer pins, retainer, and the retainer nut on valve spring unit, tighten the nut until one thread is showing out of the back of the nut.
3. Pull the trigger and install the valve seat by hand until you feel a positive stop.
4. With the trigger locked, and using a feeler gauge (feeler gauge must be placed between the retainer and gun body), tighten the retainer nut so that you have .020" spacing between retainer and gun body.
5. Unlock and depress the trigger, then torque the valve seat to 30 ft. pounds.

# GUN DIAGRAM AND PARTS LIST

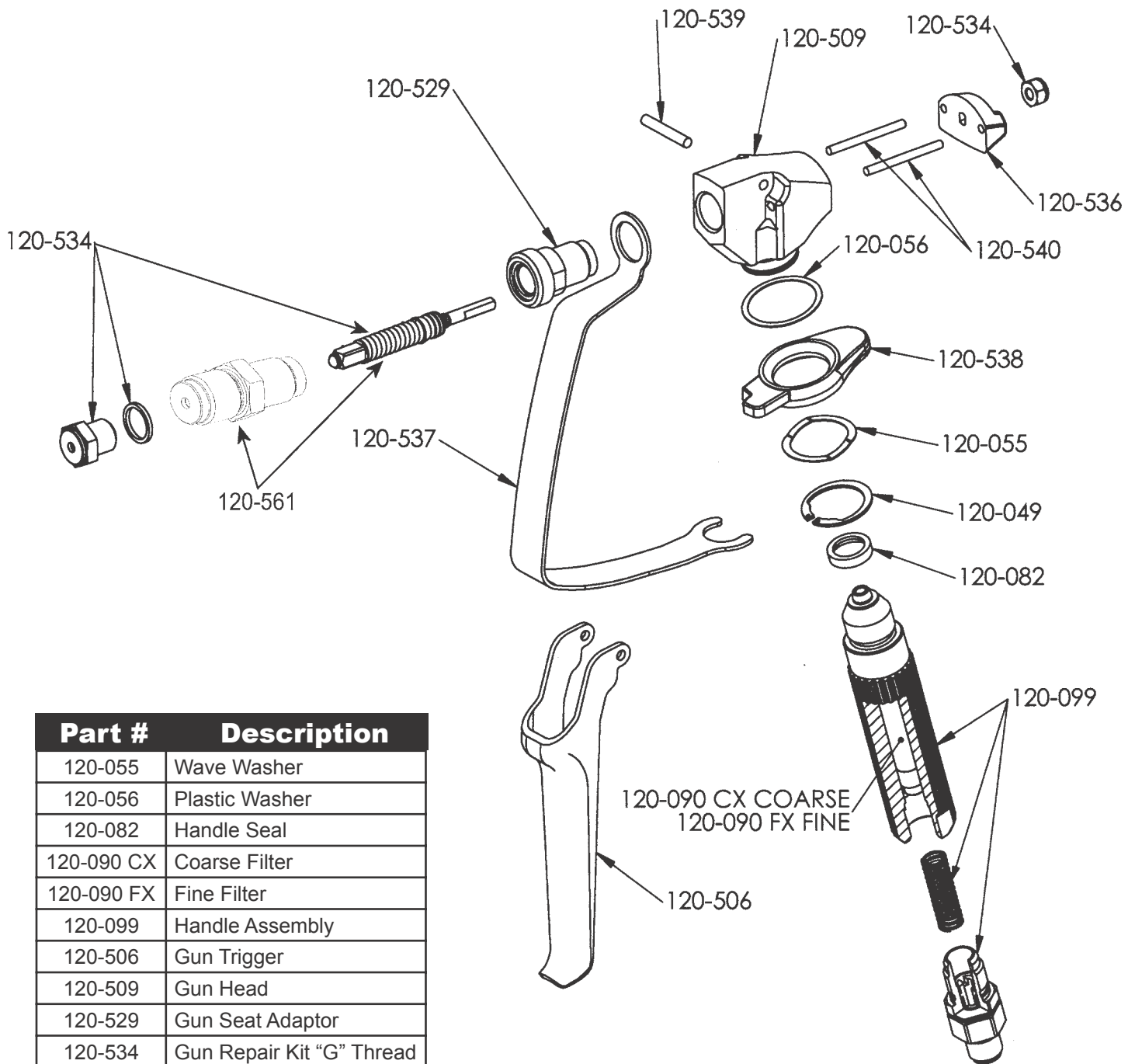

Part #	Description
120-055	Wave Washer
120-056	Plastic Washer
120-082	Handle Seal
120-090 CX	Coarse Filter
120-090 FX	Fine Filter
120-099	Handle Assembly
120-506	Gun Trigger
120-509	Gun Head
120-529	Gun Seat Adaptor
120-534	Gun Repair Kit "G" Thread
120-536	Gun Plate
120-537	Trigger Lock
120-538	Gun Trigger Lock
120-539	Pivot Trigger Pin
120-540	Actuator Pin (2)
120-561	Gun Repair Kit "F" Thread

# QUICK REFERENCE & SAFETY WARNINGS

## SPRAY GUN

Attach spray gun to airless hose & tighten fittings securely. The trigger lock should always be set (locked) when the gun is not being triggered.



## MAJOR COMPONENTS OF SPRAY GUN AND REVERSIBLE SPRAY TIP

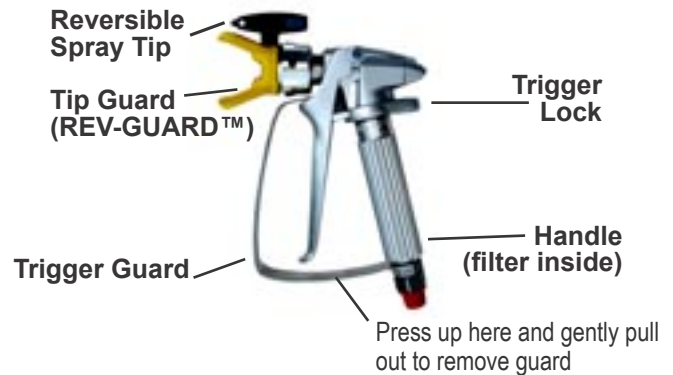

## SPRAY TIP ASSEMBLY

1. Be sure the pressure relief procedure is followed before assembling tip and housing to the gun.
2. Insert REV-TIP™ cylinder into REV-GUARD™ (guard housing assembly).
3. Guide the metal seat into REV-GUARD™ (guard housing assembly) through the retaining nut and turn until it seats against the cylinder.
4. Insert the O-ring gasket onto the metal seat so that it fits into the grooves.
5. Finger tighten the REV-GUARD™ retaining nut onto the gun.
6. Turn guard in the desired position.
7. Completely tighten the retaining nut.

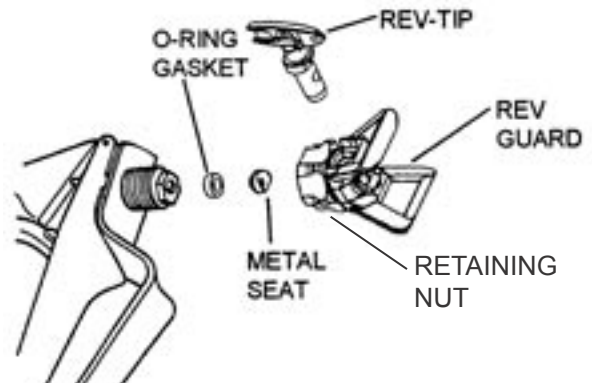

## TO REMOVE CLOGS FROM SPRAY TIP

1. Lock gun trigger.
2. Turn REV-TIP™ handle 180 degrees.
3. Disengage trigger lock and trigger gun into pail.
4. If the REV-TIP™ handle appears locked (resists turning), loosen the retaining nut. The handle will now turn easily.
5. Engage trigger lock and return handle to the spray position.

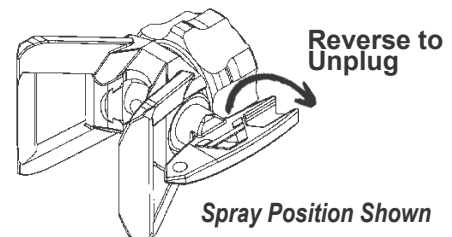

## WARNING

- ⚠ High pressure spray can cause extremely serious injuries such as amputation.
- ⚠ Handle the spray gun as you would a loaded firearm!! Read and understand all instruction manuals, tags, warnings, users guides & labels supplied with the spray gun, airless pump, hoses, spray tips & any other attachments before operating equipment.
- ⚠ Learn & follow “Pressure Relief Procedure” of the equipment in use. Never attempt to change or clean the spray tip or service unit & gun without first releasing pressure. If “Pressure Relief Procedure” is not known, contact pump manufacturer for instruction. Never leave pressure in the system while not in use.
- ⚠ Airlessco spray guns are designed for use with Airlessco spray tips only.
- ⚠ If any other attachments are used, the spray gun is considered to be modified and safe operation is now limited to the safety of the attachment.
- ⚠ For safe renting of airless equipment, use rental instructions, warnings and forms supplied by airless pump manufacturer
- ⚠ Be sure that all safety devices are operating properly before each use.

# QUICK REFERENCE & SAFETY WARNINGS

## NEVER OPERATE GUN WITHOUT TIP GUARD ATTACHED

### ⚠️ INJECTION HAZARD

Fluid under high pressure from spray or leaks can penetrate the skin & cause serious injury & the need for amputation.

NEVER point the spray gun at anyone or any part of the body.  
NEVER put hand or fingers over the spray tip. Do not use a rag over your fingers, paint would penetrate through and onto fingers.

NEVER try to stop leaks with your hand or body.

NEVER wipe off build up around spray tip.

ALWAYS remove the tip from the gun to clean it. After following Pressure Relief Procedure!!

NEVER operate spray gun under pressure without spray tip.

NEVER try to “blow back” paint - this is not an air spray gun.

### ⚠️ MEDICAL TREATMENT

If any fluid appears to penetrate your skin, get EMERGENCY CARE AT ONCE. DO NOT TREAT AS A SIMPLE CUT. Tell doctor what fluid was injected & have him call for treatment instructions at NATIONAL POISON CENTER NETWORK (412) 681-6669.

### ⚠️ SPRAY GUN SAFETY

ALWAYS SET SAFETY LOCK ON THE GUN IN LOCKED POSITION WHEN NOT IN USE AND BEFORE SERVICING & CLEANING.

DO NOT remove or modify any part of the gun.

Check operation of gun safety devices before each use.

### ⚠️ TIP GUARD

NEVER operate gun without tip guard attached.

NEVER modify or alter tip guard.

NEVER use Airlessco tip guard on other attachments.

Airlessco’s tip guard is designed for use with standard spray tips only. When using other than standard spray tips, consult manufacturer of such attachment for recommended tip guard & safety instructions.

### ⚠️ SPRAY GUN SAFETY

NEVER work on gun when connected to hose.

Be very careful when removing hose or spray tip from gun.

A plugged line contains fluid under pressure. If tip or line is plugged, follow the Pressure Relief Procedure for the pump you’re using.

### ⚠️ SPRAY TIP SAFETY

Use extreme caution when cleaning or changing spray tips. If spray tip clogs while spraying, engage the gun safety latch and ALWAYS follow “PRESSURE RELIEF PROCEDURE” before removing spray tip to clean it.

### ⚠️ CLEANING

Refer to pump manufacturer’s recommendation for cleaning the system. Release pressure from pump and hose, remove spray tip and flush with lowest possible pressure.

### ⚠️ GENERAL PRECAUTIONS

NEVER alter equipment in any manner.

NEVER use around children.

NEVER allow another person to use sprayer.

ALWAYS use face mask while spraying.

NEVER leave sprayer unattended with pressure in system.

## FIRE EXPLOSION WARNING

### SPRAYING VAPORS + STATIC SPARKING = FIRE/EXPLOSION

#### PREVENT FIRE AND EXPLOSION BY REDUCING STATIC SPARKING AND ELIMINATING VAPORS BY FOLLOWING THESE WARNINGS

ALWAYS be sure all equipment, paint bucket and object being sprayed are properly grounded. ALWAYS ground sprayer, gun, paint bucket and object being sprayed. Be sure gun is grounded through hose connection.

NEVER spray in closed area. Ventilation must be adequate to remove vapors.

NEVER keep flammable materials in spray area.

NEVER spray highly flammable liquids.

ALWAYS use only high pressure conductive airless hoses with static wire approved for 3000 psi. Never exceed 500 feet of hose.

NEVER SMOKE IN SPRAYING AREA.

ALWAYS ensure properly maintained fire extinguishing equipment is available.

NEVER spray in vicinity of open flame or other sources of ignition such as water heaters and furnaces.

ALWAYS locate the sprayer and electrical outlets in use at least 25 feet away from spray area in well ventilated area.

Do not plug in any electrical cords in spray area.

Follow the coating and solvent manufacture’s safety precautions and warnings.

#### HALOGENATED HYDROCARBON WARNING:

NEVER use halogenated hydrocarbon (HHC) solvents or paints that contain them in this system. Some of the most common of these solvents are: Carbontetrachloride, Chlorobenzene, Dichloroethane, Dichloroethyl Ether, Ethyl bromide, Ethylchloride, Tetrachloethane.

#### FLUSHING AND CLEANING CAN CREATE STATIC SPARKING IF DONE IMPROPERLY!

NEVER spray solvents under pressure through spray tip.

Follow Pressure Relief Procedure and remove spray tip for cleaning.

Use LOWEST POSSIBLE PRESSURE when flushing and cleaning.

Hold gun firmly against a metal waste container to reduce spark possibility.

NEVER use cleaning solvents with flash points below 140 degrees F. Some of these are: acetone, benzene, ether, gasoline, naphtha. Consult your supplier to be sure.

✂️ --- Cut along line and keep handy for Quick Reference --- ✂️

# REV-TIP™ SPRAY TIP SIZE CHART

Part Number 560-xxx

For sizes not shown, call factory for availability.

### TIP IDENTIFICATION:

**1st 3-digits** identifies it as a REV-TIP™ for airless paint spraying (P.N. 560-xxx) or a REV-TIP™ for airless line striping (P.N. 562-xxxST).

**4th digit** is the fan width - the number is half the fan width, e.g., 5 means a 10" fan. Exception are the "W" prefix tips which indicate a wide spray pattern.

**5th and 6th digits** are for the orifice size and is measured in thousandths of an inch, e.g., 17 = 0.017 inch - The higher the number, the larger the tip.

Rev-Tip™ for Painting Fan Width (12" from surface)		SPRAY TIP - ORIFICE SIZE (Inches)													
in.	(mm)	.009	.011	.013	.015	.017	.019	.021	.023	.025	.027	.029 .031	.035	.039	.041
4-6	102-152	209	211	213	215	217	219	221	223	225	227	229			
6-8	152-203	309	311	313	315	317	319	321	323	325	327		335		
8-10	203-254	409	411	413	415	417	419	421	423	425	427	431			
10-12	254-305		511	513	515	517	519	521	523	525	527	531	535		
12-14	305-356	<i>Fine Finish Tips Below!</i>		613	615	617	619	621	623	625	627	631	635	639	641
14-16	356-406				715	717		721						739	741
16-18	406-457				815		819	821				831			
20-24	508-610							W21	W23	W25					
<b>Gun Filter</b>	C= Coarse - 60 mesh F= Fine - 100 mesh		F	F	F,C	C	C	C	C	REMOVE FILTER					
<b>Wood Interior</b>	Lacquer, Varnish Stain, Sealer Enamel		•	•	•										
<b>Wood Exterior</b>	Exterior Stain Vinyl, Acrylic, Latex				•	•		•	•						
<b>Masonry</b>	Vinyl, Oil Base Alkyd Latex, Acrylic Block Filler Elastomer				•	•	•	•	•	•	•	•	•	•	•
<b>Ceiling</b>	Hi Build, Mil White							•	•						
<b>Structural Steel</b>	Heavy Coatings							•	•	•	•	•	•	•	•
<b>Water Flow Rate</b>	(gpm) (water @ 2000psi, 138 bar)		.12	.18	.24	.31	.38	.47	.57	.67	.77	1.03	1.31	1.63	1.80
	(lpm)		.49	.69	.91	1.17	1.47	1.79	2.15	2.54	2.96	3.90	4.98	6.17	6.81
<b>Paint Flow Rate</b>	(gpm) (latex paint @ 2000psi, 138 bar/1.36 spec. gr.)		.10	.15	.21	.27	.33	.40	.49	.58	.66	.88	1.12	1.39	1.54
	(lpm)		.38	.57	.79	1.02	1.25	1.51	1.85	2.20	2.50	3.33	4.24	5.26	5.83
<b>Pump Minimum Output*</b>	(gpm) (lpm)		.25	.25	.33	.40	.50	.60	.75	.88	1.0	1.25	1.5	2.0	2.2
			1.0	1.0	1.25	1.5	1.9	2.3	2.8	3.3	3.8	4.7	5.7	7.5	8.2



### REV-TIP™ For Paint Spraying

**P.N. 560-xxx**  
Includes Rev-Tip™,  
Metal Seal & O-Ring Seal.

Sample:

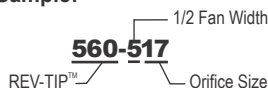

**NEW!**

### Fine Finish REV-TIP™

Part # 571-xxx

Double orifice design for lower pressure spraying when you need a smoother finish on interior trim, cabinetry, shutters, and doors.

Fan Width Inches (mm)	Orifice Size		
	.010	.012	.014
4-6	102-152	210	212 214
6-8	152-203	310	312 314
8-10	203-254	410	412 414

### XTEND-A-POLE SYSTEM™ Tip Extensions - Complete with Patented SPRAY CLEAN REV-GUARD



### TIP EXTENSIONS, G-THREAD

032-170 6" Long    032-172 18" long  
032-171 12" Long    032-173 24" Long

### SWIVEL & EXTENSION, G-THREAD

032-035 Swivel only  
032-184 Swivel with 36" Pole

### EXTENSIONS (BARE POLES)

Add Tip Extension or Swivel Extension to create desired length

032-053 24" Long  
032-054 36" Long

### HIGH PRESSURE HOSE



**Strong yet flexible, suitable for use with airless spray equipment up to 3300 PSI**  
Part No:

100-012 3/16" x 4' Whip Hose  
100-011 1/4" Hose, 50 Ft.  
100-023 3/8" Hose, 50 Ft.  
100-037 1/2" Hose, 50 Ft.  
100-219 Hose Cover Roll



100-010 1/4" Hose Connector  
100-009 3/8" Hose Connector

### REV-GUARD™



- Aerodynamics eliminates drips
- Super compact

**Part # 561-001**

11/16-16 "F" Thread. Fits: Airlessco, and some ASM, Wagner, and Campbell Hausfeld.

**Part # 561-002**

7/8-14 "G" thread. Some: Graco, Wagner, Titan, Airlessco.



# **IMPORTANT**



**READ, LEARN &  
UNDERSTAND ALL  
LABELS, INSTRUCTION  
MANUALS & SAFETY  
WARNINGS BEFORE  
USING THIS PRODUCT.**